

# **HEBER PUBLIC UTILITY DISTRICT REQUEST FOR PROPOSALS FOR ESTANCIA PARK IRRIGATION EFFICIENCY PROJECT**

August 14, 2024

## **INTRODUCTION / PROJECT DESCRIPTION**

The Heber Public Utility District intends to replace sprinklers, valves, and control for the automatic watering system in Estancia Park. Estancia Park is a seven (7) acre park and stormwater retention basin that is located at 84 W. Correll Road. In order to increase efficiency of the sprinkler system and promote water conservation, the irrigation sprinklers, valves, and controls will be replaced.

This project will upgrade the irrigation system at Estancia Park to be more efficient and will directly contribute to water savings, installing high efficiency rotary nozzles, which uniformly deliver water at a lower rate than flood irrigation, significantly reducing runoff and erosion.

## **PROPOSAL SUBMISSION AND CONTACT INFORMATION**

Sealed proposals will be received by the **Heber Public Utility District**, as per the information noted below. At such time bid proposals will be publicly opened and read aloud.

### **Submit Proposals to:**

**Heber Public Utility District  
Attention: Madeline Dessert, General Manager  
Re: Estancia Park Irrigation Efficiency Project  
1078 Dogwood Road, Suite 103  
Heber, CA 92249  
Ph: (760) 482-2440  
[www.heber.ca.gov](http://www.heber.ca.gov)**

**Bid Deadline:  
3:00 P.M. Pacific Standard Time  
Thursday, September 5, 2024**

No bid proposal will be considered for award unless submitted on the Bid Proposal Form furnished by the Heber Public Utility District. Forms shall be completed and signed by the bidder and delivered prior to the time and date specified in this Request for Proposals (RFP).

Contact Persons:

Madeline Dessert, General Manager / Juny Marmolejo, THG Project Engineer  
Phone: 760-336-1572 / Phone: 760-562-3635  
Email: [mdessert@heber.ca.gov](mailto:mdessert@heber.ca.gov) / Email: [jmarmolejo@theholtgroup.net](mailto:jmarmolejo@theholtgroup.net)

## SCOPE OF WORK DESCRIPTION

The Scope of Work is to replace the following irrigation system components of the Heber Public Utility District's Estancia Park.

- Replacement of existing outdoor controller, with a new outdoor controller in metal panel for operation of valves. Controller(s) shall operate Bluetooth controllers located at valve boxes throughout the park. Controller to remain in the same location at the southerly end of the park.
- Replacement of 42 existing control valves that are located throughout the park. Each new control valve is to be equipped with Bluetooth Battery Operated Irrigation Controller.
- Replacement of 126 existing sprinkler heads that are located throughout the park.

The project will require the removal and disposal of the existing control panel, control valves, wiring and sprinkler heads. The replacement control panel, control valves, wiring with casing and sprinkler heads are to be of new material.

The contractor will be required to close the retention basin area of the park during construction. There is existing fencing around the park but will be required to provide additional fencing (temporary) and security of the park area.

The contractor will provide a fully automated and operational park irrigation system. The irrigation system is to be set and calibrated to provide appropriate irrigation of the existing lawn and watering schedule. The contractor will provide an operations plan / manual of the automated control system and provide appropriate training to HPUD landscape representatives for the operation and maintenance of the control panel, valves and sprinkler heads.

The Vicinity Map and Existing Site Plan of the park are provided as Exhibit A. The control panel is located at the south end of the park, while the control valves and sprinkler heads are located throughout the entire area of the park. A sketch illustrating the location of the control panel (timer), and control valves are included in Exhibit A.

## **BIDDING PROCEDURES**

1. Attention of bidders is especially directed to the specifications which, in addition to the bid proposal and these instructions, are the basis for evaluation and will be part of any contract with the successful bidder.
2. The contract will be awarded to the lowest, responsive, responsible bidder, provided that all bidders acknowledge the right of the Heber Public Utility District (District) to accept or reject any and all bids and to waive any informality or irregularity in any bid received.
3. Inquiries or questions based on alleged patent ambiguity of the Bid must be communicated as a bidder inquiry prior to bid opening. Any such inquiries or questions, submitted after bid opening, will not be treated as a bid protest. Any deviation from the specifications in this notice shall be proper reason for rejection of all or any part of the bid proposal.
4. Securing Documents: All specification documents are included in this RFP.
5. Proposals: Bids to receive consideration shall be made in accordance with the following instructions:
  - a. Bids shall be made upon the Bid Proposal Form that is attached to this RFP. All bids must be properly executed. Bids shall be written in ink or typed. Quotations are to be verified before submission as they cannot be corrected after the bids are opened. The signatures of all persons shall be in longhand. The completed proposal shall be without interlineations, alternations or erasures. No oral or telegraphic modification will be accepted.
  - b. Before submitting a proposal, the bidder shall carefully examine the Specifications, Terms and Conditions, and any other applicable documents. The bidder shall fully inform themselves as to all existing site conditions and limitations and shall include in the bid a sum to cover the cost of all items included in the specifications. The bidder shall conduct a site visit to review the existing site conditions inclusive of the existing irrigation system that is to be replaced. Access to the site is to be coordinated with the District.
  - c. No charge for packing, draying, postage, express or for any other purpose will be allowed over and above the prices quoted on the Bid Proposal Form.
  - d. Bid Proposal Forms shall be delivered to the Heber PUD, Attention: Madeline Dessert, General Manager on or before the day and hour set for the opening bids.

## **QUALIFICATION OF BIDDERS**

Each bidder, by submitting its bid, represents that it is qualified to perform the scope of the work for which it submits its proposal. It further represents that it can do so in the time specified.

Each bidder shall have a California Class C – 27 Landscaping Contractor contractor's license. Each bidder shall submit with its proposal, the Experience Statement form included within the Proposal Form.

The District may make such investigations as deemed necessary to determine the ability of the bidder to provide the specified Scope of Work, and the bidder shall furnish to the all such information and data for this purpose as the District may request. The District reserves the right to reject any bid if the evidence submitted by, or investigation of such bidder fails to satisfy the District that such bidder is properly qualified to carry out the obligations of the contract and to complete the work contemplated therein. Conditional or qualified bids will not be accepted.

The Bidder shall have experience in work of nature similar in type and magnitude to that set forth in the specification extends over a period of 5 years.

### **TERMS OF DELIVERY/PAYMENT**

Bidders agree that Scope of Work must be delivered to HPUD premises upon a scheduled date (20 days from the date of Agreement) to 84 Correll Road, Heber CA, 92249. If for any reason the bidder fails to deliver the Scope of Work within the terms specified above, the contract shall be deemed void and HPUD, at its sole discretion, may offer award to the second lowest bidder, or re-advertise material for a new bid. The successful bidder is responsible for all costs involved in/and for providing the Scope of Work.

### **LABOR COMPLIANCE**

This Public Works project is funded by Heber Public Utility District and requires compliance with the California Labor Standards, California Code of Regulations pertaining to Public Works projects, California Labor Codes and the California prevailing wage requirements with special attention to CLC 1720, CLC 1727, CLC 1729, CLC 1770, CLC 1777.5, CLC 1775, CLC 1810 through 1815 and CLC 3700.

### **INSURANCE REQUIREMENTS**

The successful bidder will be required to provide insurance documentation.

The Contractor shall purchase and maintain such insurance as will protect him/her from claims set forth below which may arise out of or result from the Contractor's execution of the work whether such execution be by itself or by any subcontractor or by anyone directly or indirectly employed by any of them, or by anyone for whose acts any of them may be liable. Such claims shall include:

- a. Claims under workmen's compensation, disability benefits and other similar employee benefit acts.
- b. Claims for damages because of bodily injury, occupational sickness or disease, or death of his/her employees.
- c. Claims for damages because of bodily injury, sickness or disease, or death of any person other than his/her employees.
- d. Claims for damages insured by usual personal injury liability coverage which are sustained (1) by any person as a result of an offense directly or indirectly related to the employment of such person by the Contractor, or (2) by any other person.
- e. Claims for damages because of injury to or destruction of tangible property, including loss of use resulting therefrom.

Certificates of Insurance acceptable to the Heber Public Utility District shall be filed with the District prior to commencement of the work.

The Contractor shall procure and maintain, at his/her own expense, during the contract time, liability insurance as hereinafter specified.

Contractor's General Public Liability and Property Damage Insurance including vehicle coverage issued to the Contractor and protecting him from all claims for destruction of or damage to property, arising out of or in connection with any operations under the contract documents, whether such operations be by himself or by any subcontractor under him or anyone directly or indirectly employed by the Contractor or by a subcontractor under him. Insurance shall be written with a limit of liability of not less than \$1,000,000.00 for all damages arising out of bodily injury, including death, at any one time resulting therefrom, sustained by any one person in any one accident; and a limit of liability of not less than \$1,000,000.00 aggregate for any such damages sustained by two or more persons in any one accident. Insurance shall be written with a limit of liability of not less than \$1,000,000.00 for all property damage sustained by any one person in any one accident; and a limit of liability of not less than \$1,000,000.00 for all aggregate for any such damage sustained by two or more persons in any one accident. The Policy shall name as the insured the Contractor, the Heber Public Utility District.

The Contractor shall acquire and maintain Extended Coverage insurance upon the project to the full insurable value thereof for the benefit of the Heber Public Utility District, the Contractor, and subcontractors as their interest may appear.

The Contractor shall procure and maintain at his/her own expense, during the contract time, in accordance with the provisions of the laws of the state in which the work is performed, Worker's Compensation Insurance, including occupational disease provisions for all of his/her employees at the site of the project and in case any work is sublet, the Contractor shall require such subcontractor similarly to provide Worker's Compensation Insurance, including occupational disease provisions for all of the latter's employees unless such employees are covered by the protection afforded by the Contractor.

## **TECHNICAL SPECIFICATION**

1. A single bidder, Class C-27 Landscaping Contractor, that is licensed in the state of California, shall be responsible for the design, permitting (as applicable), supply and construction of the Scope of Work specified in this RFP.
2. Scope of Work: The contractor shall conduct the project Scope of Work as described in the Scope of Work Description section of the RFP.
3. Design: The design is to be reviewed and approved by the Heber Public Utility District.
4. Field Measurement: Verify the layout information for the existing and new layout of the control valves and sprinkler heads.
5. Warranty: A 1 year warranty shall be provided for the project.
6. As-Builts: The contractor shall provide the Heber Public Utility District a complete set of As-Built drawings of the completed scope of work.

**HEBER PUBLIC UTILITY DISTRICT  
REQUEST FOR PROPOSALS FOR  
ESTANCIA PARK IRRIGATION EFFICIENCY PROJECT**

**BID PROPOSAL FORM – PAGE 1**

BIDDER'S NAME: \_\_\_\_\_

\_\_\_\_\_

TOTAL BID COSTS: \$ \_\_\_\_\_

**EXPERIENCE STATEMENT:**

The following contracts covering work similar in type and magnitude to that set forth in the specification have been satisfactorily completed within the last five (5) years for the following owners (person, firms or authorities): It is acceptable to provide an attached list of projects in lieu of the form below

	<b>Name of Owner</b>	<b>Tel. No.</b>	<b>Year Completed</b>	<b>Type of Work</b>	<b>Contract Amount</b>
1.					
2.					
3.					
4.					
5.					

The Bidder agrees to indemnify, and hold HPUD and its managers, directors and employees harmless from any loss, cost, expense, liability, claim, or demand, including reasonable attorney's fees, suffered by any indemnified Persons, due to, arising out of, or in connection with (i) Bidder use of services or provided by HPUD personnel, (ii) any violation of these terms and conditions by Bidder or any person acting in collusion with Bidder, (iii) any violation of applicable law or court orders by Bidder, and (iv) any negligence or willful misconduct by Bidder.

**HEBER PUBLIC UTILITY DISTRICT  
REQUEST FOR PROPOSALS FOR  
ESTANCIA PARK IRRIGATION EFFICIENCY PROJECT**

**BID PROPOSAL FORM – PAGE 2**

Company Name: \_\_\_\_\_  
\_\_\_\_\_  
\_\_\_\_\_

Business Phone: \_\_\_\_\_ Fax No. \_\_\_\_\_

California Contractor's License No.: \_\_\_\_\_

California Dept of Industrial Relations (DIR) No: \_\_\_\_\_

Name/Title of  
Contact Person: \_\_\_\_\_

Address: \_\_\_\_\_

Contact Phone: \_\_\_\_\_ Mobile No. \_\_\_\_\_

E-Mail Address of Contact Person: \_\_\_\_\_

Authorized Bidder:

\_\_\_\_\_  
Signature of Authorized Bidder

\_\_\_\_\_  
Date

The above signed, as bidder, hereby declares that the only person or persons interested in the Proposal, as principal or principals, is or are named herein and that no other person than herein mentioned has any interest in the proposal or contract to which pertains; that this Proposal is made without connection or arrangement with any other person, company, or parties making a bid or proposal and that the Proposal is in all respects fair and made in good faith without collusion or fraud. Submission of a signed proposal will be interpreted to mean that person(s) has hereby agreed to all the terms and conditions set forth in all the pages of the Request for Proposal. The signed Proposal and Heber PUD's written acceptance shall constitute a contract.



Attachment A – Exhibit Drawings.





# ESTANCIA PARK

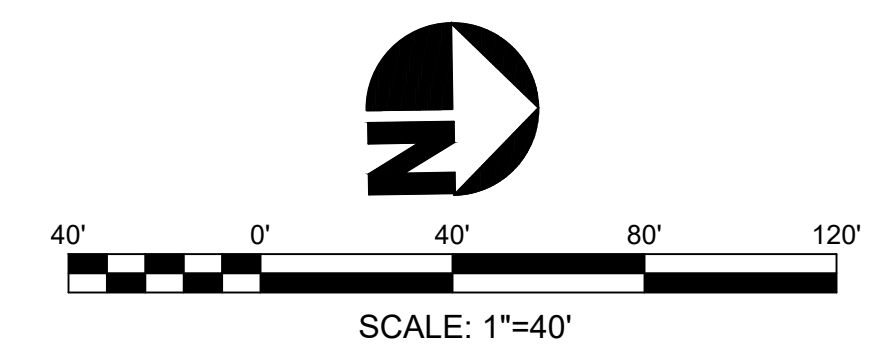

No.	REVISION	APPROVED	DATE	DESIGNED BY: JM	DRAWN BY: JM

UNAUTHORIZED CHANGES AND USES: The engineer preparing these plans will not be responsible for, or liable for, unauthorized changes to or uses of these plans. All changes to these plans must be in writing and must be approved by the preparer of these plans.

SCALE: PER PLAN	CHECKED BY: JM
BENCH MARK No.	ELEV.:
BENCHMARK	

PREPARED UNDER THE DIRECT SUPERVISION OF:

JESUS R. MARMOLEJO, P.E.

03/08/2022  
DATE

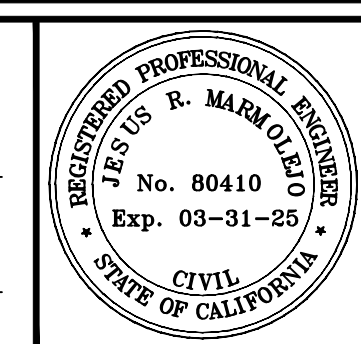

**The Holt Group, Inc.**

ENGINEERING \* SURVEYING \* CONSTRUCTION MANAGEMENT \* PLANNING

1601 N. IMPERIAL AVENUE  
EL CENTRO, CA 92243  
PHONE : (760) 337-3883  
FAX : (760) 337-5997

201 E. HOBSONWAY  
BLYTHE, CA 92225  
PHONE : (760) 922-4658  
FAX : (760) 922-4660

PROJECT TITLE : HEBER PUBLIC UTILITY DISTRICT  
ESTANCIA PARK IRRIGATION EFFICIENCY PROJECT

PROJECT NUMBER : 744.100

SHEET CONTENT :

SHEET NO. \_\_\_\_\_  
OF \_\_\_\_\_  
SHEETS

Date Canal

22  
23  
24

18  
19  
20  
21

25

17

12  
13  
14  
15  
16

28  
27  
26

29

10  
11

31  
30

32

6  
7  
8  
9

35  
34  
33

36

5

37

4

3

2

1

42  
41

40

39

38

Location of controller

Timer

N Cherry Ave

N Cherry Ave

W Correll Rd

Date

